

JVC



ENGLISH

VIDEO CASSETTE RECORDER

HR-J73MS

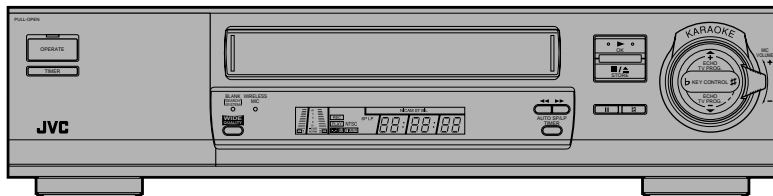
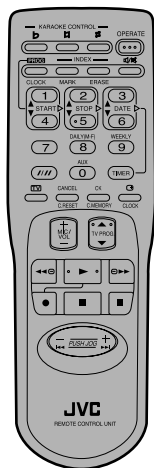

Hi-Fi VHS
PAL NTSC

INSTRUCTIONS

Table of Contents

Thank you for purchasing this JVC video cassette recorder. To ensure optimum performance of this unit, please read this instruction manual thoroughly.

Precautions	2
Controls, Indicators and Terminals	4
Installations	7
Setting the On-screen	8
Setting the Clock	9
Setting the Tuner	9
The Video Cassette	10
B.E.S.T. Picture System	11
Playback	12
Recording	14
Timer Recording	16
Karaoke	18
Editing	24
Information on Multi-System Compatibility	25
Troubleshooting	27
Specifications	28

Features

Karaoke With Various Functions

You can fully enjoy karaoke video with a wide selection of pro-style features including Karaoke Control Centre, microphone, karaoke remote operation, and more.

Multi-System Compatibility

You can enjoy watching programmes and software from many different countries.

Multi-System Tuner (D/K, I)

Makes it possible to receive TV programmes in Hong Kong and most of other countries in Asia.

Precautions

Safety precautions

The rating plate and the safety caution are on the rear of the unit.

WARNING: DANGEROUS VOLTAGE INSIDE

WARNING: TO PREVENT FIRE OR SHOCK HAZARD, DO NOT EXPOSE THIS UNIT TO RAIN OR MOISTURE.

The OPERATE button does not completely shut off mains power from the unit, but switches operating current on and off.

CAUTION:

- When you are not using the recorder for a long period of time, it is recommended that you disconnect the power cord from the AC outlet.
- Dangerous voltage inside. Refer internal servicing to qualified service personnel. To prevent electric shock or fire hazard, remove the power cord from the AC outlet prior to connecting or disconnecting any signal lead or aerial.
- Use the conversion plug (provided) depending on the type of your AC wall outlet.
- This unit operates on voltage of AC110 – 240V~(Rating), AC90 – 260 V~(operating), 50/60 Hz with automatic switching.



- Only cassettes marked "VHS" can be used with this video cassette player.

Importants

- This recorder can also receive SECAM colour television signals for recording and playback.
- Recordings made of SECAM television signals produce monochrome pictures if played back on another video recorder of SECAM standard, or do not produce normal colour pictures if played back on another video recorder of PAL standard.
- SECAM prerecorded cassettes or recordings made with a SECAM video recorder produce monochrome pictures when played back with this recorder.
- Video tapes recorded with this video recorder in the LP (Long Play) or EP (Extended Play) mode cannot be played back on a single-speed video recorder.
- It may be unlawful to record or playback copyrighted material without the consent of the copyright owner.

Precautions

Please follow these precautions. Not doing so may result in damage to the recorder, remote control, or video cassette.

- **Avoid extreme heat and direct sunlight.**
- **Avoid extreme cold.**
- **Avoid extreme humidity.**
- **Avoid dust.**
- **Avoid places subject to vibrations.**
- **Avoid strong magnetic fields.**
- **Do not block the recorder's ventilation openings.**
- **Do not place anything heavy on the recorder or remote control.**
- **Do not place anything which might spill on top of the recorder or remote control.**
- **Do not place the recorder on cushions, pillows, or thick carpeting.**
- **Use the recorder in a stable, horizontal position only.**
- **Place cassettes in cassette cases and store vertically.**

When transporting

- Be sure to remove cassette from recorder before packing.
- Avoid violent shocks to the recorder during packing and transport.

Beware of moisture condensation

Moisture in the air will condense on the recorder when you move it from a cold place to a warm place, or under extremely humid conditions — just as water droplets form on the surface of a glass filled with cold liquid. Moisture condensation on the head drum will cause damage to the tape. In conditions where condensation may occur, keep the recorder's power turned on for a few hours to let the moisture dry.

Special note on head cleaning

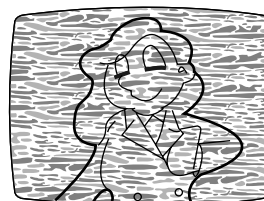

Accumulation of dirt and other particles on the video heads may cause the playback picture to become blurred or interrupted. Although this model is equipped with a built-in head cleaner which automatically cleans the heads, reducing the likelihood of dirty heads, if such troubles are encountered please consult the nearest JVC dealer.

Auto Head Cleaner

A built-in head cleaner automatically cleans the video heads and head drum whenever a tape is loaded or unloaded to reduce head clogging.

ATTENTION:

This recorder contains microcomputers. External electronic noise or interference could cause malfunctioning. In such cases, switch the power off and unplug the power cord. Then plug it in again and switch on. Take out the cassette. After checking the cassette, operate the unit as usual.

Controls, Indicators and Terminals

Front panel

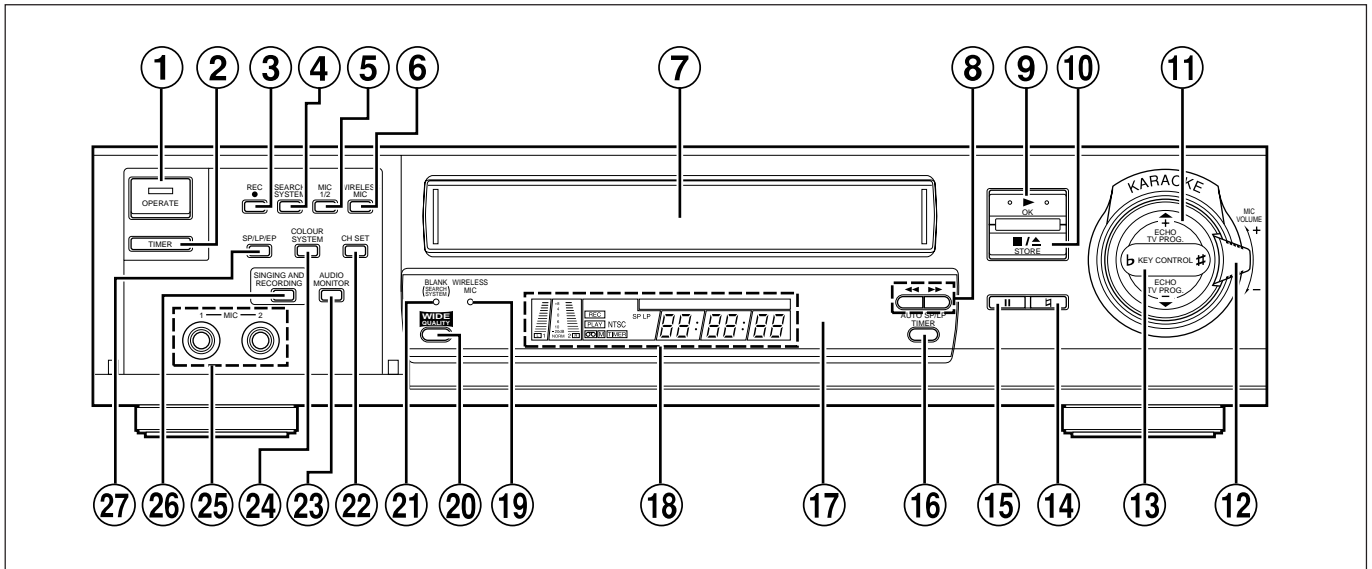

- | | |
|--|---|
| ① OPERATE button and indicator | ⑮ Pause/Still ■■ button |
| ② TIMER button | ⑯ AUTO SP/LP TIMER button and indicator |
| ③ Record ● button | ⑰ Infrared beam sensor window |
| ④ SEARCH SYSTEM button | ⑱ Display panel |
| ⑤ MIC select button | ⑲ WIRELESS MIC indicator |
| ⑥ WIRELESS MIC button | ⑳ WIDE QUALITY button and indicator |
| ⑦ Cassette loading slot | ㉑ BLANK SEARCH SYSTEM indicator |
| ⑧ Fast forward ►►/Rewind ◀◀ Search buttons | ㉒ Channel setting button |
| ⑨ Play ►/OK button | ㉓ AUDIO MONITOR button |
| ⑩ Stop/Eject ■/▲/STORE button | ㉔ COLOUR SYSTEM button |
| ⑪ ECHO/TV PROG. +/- button | ㉕ MIC input terminals |
| ⑫ MIC VOLUME control | ㉖ SINGING AND RECORDING button |
| ⑬ KEY CONTROL b/# button | ㉗ Tape speed (SP/LP/EP) button |
| ⑭ KEY CONTROL h button | |

WARNING of cassette loading slot

- Do not insert fingers or foreign objects into the cassette loading slot since this could lead to injury or damage to the mechanism. Be especially careful with children.
- Do not try to pull out a cassette once automatic loading has started.

Controls, Indicators and Terminals (cont'd)

Display panel

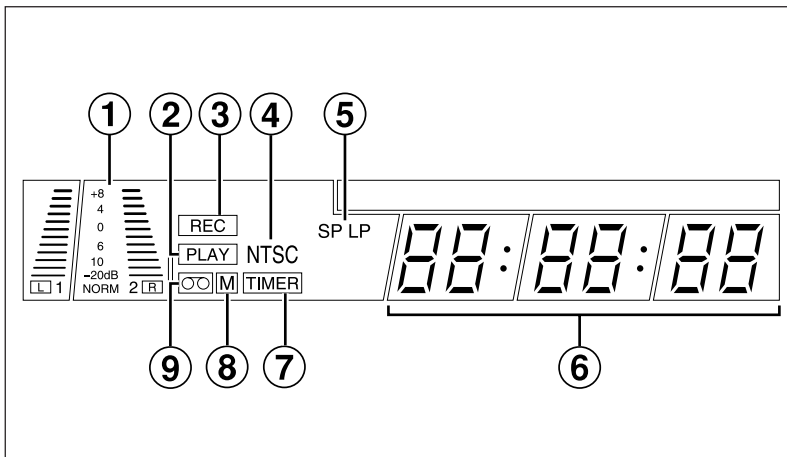

- ① Karaoke multi level indicator
- ② PLAY indicator
- ③ REC indicator
- ④ NTSC indicator
- ⑤ Tape speed (SP/LP) indicator
- ⑥ Switchable display
 - Channel
 - Clock
 - Instant timer recording time
 - Real time tape counter
- ⑦ TIMER indicator
- ⑧ Counter memory indicator
- ⑨ Cassette loaded mark

Rear panel

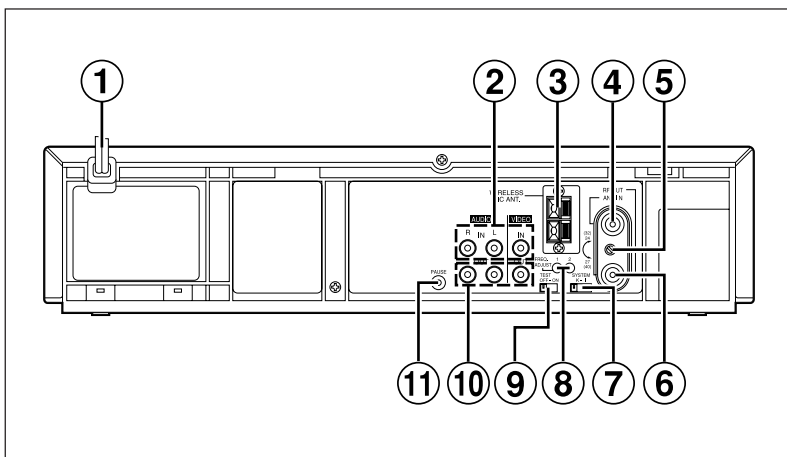







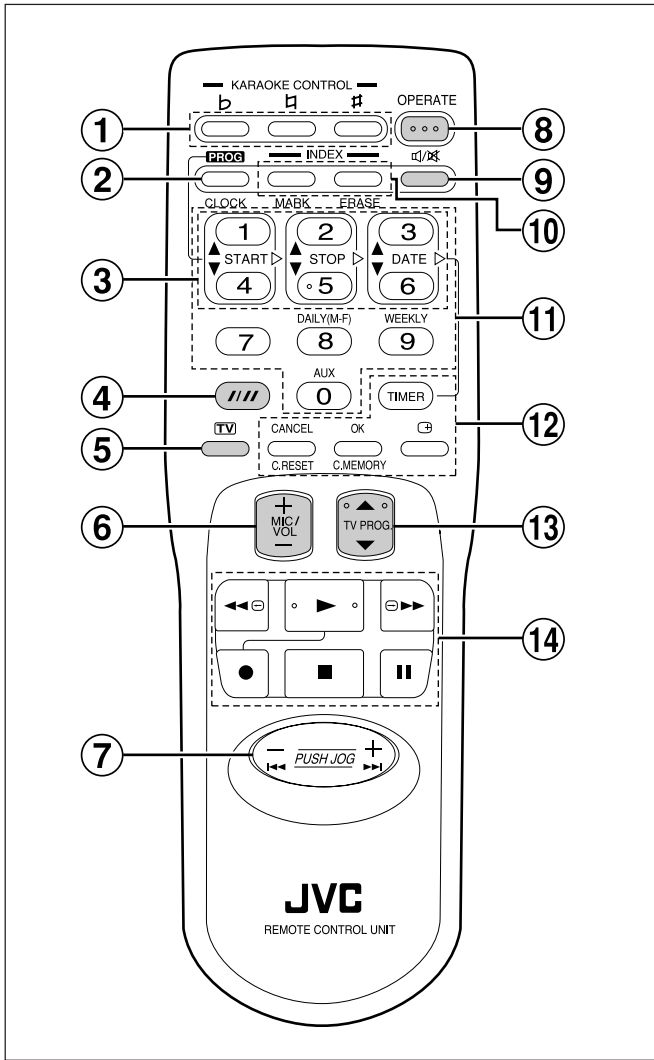





- ① Power cord
- ② VIDEO/AUDIO input terminals
- ③ Wireless MIC antenna terminals
- ④ Antenna input terminal
- ⑤ Channel adjustment screw
- ⑥ RF output terminal
- ⑦ RF output system select switch
- ⑧ MIC Frequency Adjustment screws
- ⑨ RF test output switch
- ⑩ VIDEO/AUDIO output terminals
- ⑪ PAUSE terminal







Controls, Indicators and Terminals (cont'd)

Wireless remote control



You can use these buttons  to operate your JVC TV.

- ① KARAOKE CONTROL buttons  p.21
- ② PROG/CLOCK button  p.16
- ③ Clock/Timer set buttons  p.9
- ④ SP/LP/EP/Auto tracking  button  p.12
- ⑤ TV control button
- ⑥ MIC/TV volume +/- button
- ⑦ PUSH JOG   button  p.12
- ⑧ OPERATE button
- ⑨ Audio monitor/TV sound mute  button
- ⑩ INDEX MARK/ERASE buttons  p.13
- ⑪ Multi-Purpose NUMBER buttons
- ⑫ Timer, O.S.D. setting and Counter operation buttons
- ⑬ TV program   button
- ⑭ **Basic operation buttons**

	Play
	Rewind
	Fast Forward
	Record
	Stop
	Pause/Still

How to Use

The remote control can operate most of your video recorder's functions, as well as the basic functions of designated JVC TV sets.

- Point the remote control toward the sensor window.
- The maximum operating distance of the remote control is about 8 m.



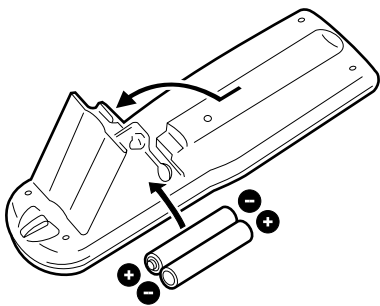

Installing Batteries



- 1 Open the battery compartment cover.
- 2 Insert 2 "AAA/UM-4"-size batteries (provided) in the correct directions.
- 3 Replace the cover.

TV Operation

You can also use the recorder's remote control to operate a JVC television.

To operate your TV, press and hold down the TV button while you press OPERATE, or TV PROG.  , or VOLUME +/-, or  (to select either Main or Sub programmes), or  (to mute the TV's sound) button .

- TV channel cannot be changed using the NUMBER buttons.

Installations

Make sure that the power to the video cassette recorder and TV is off before making the following connections.

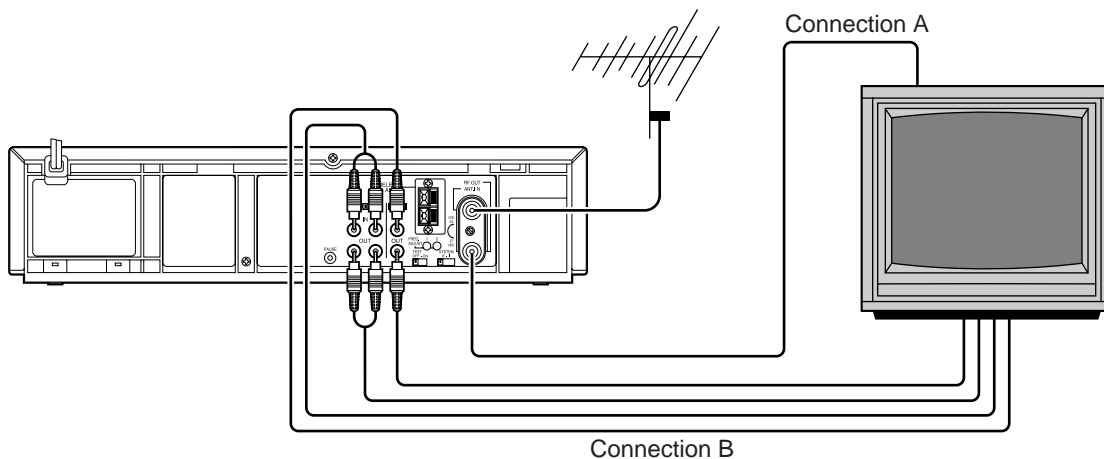

Connection A (basic)

In order to use the video cassette recorder it must be connected between the antenna and the TV.

- 1 Connect your TV antenna cable to the video cassette recorder's antenna input terminal.
- 2 Connect one end of the provided RF antenna cable to the video cassette recorder's RF output terminal and the other end to the TV's antenna terminal.
- 3 Connect the power cord to your household AC outlet.

Connection B

For connection with a TV that has VIDEO/AUDIO IN/OUT terminals. Use RCA type pin connection cords (available from audio/video stores) for connection. This connection is in addition to connection A.

- 1 Follow steps 1 and 2 of "Connection A".
- 2 Connect the TV's VIDEO output and AUDIO output terminals to the video cassette recorder's VIDEO input and AUDIO input terminals.
- 3 Connect the TV's VIDEO input and AUDIO input terminals to the recorder's VIDEO output and AUDIO output terminals.
- 4 Connect the power cord to your household AC outlet.

Note:

- Use the conversion plug (provided) depending on the type of your AC wall outlet.

Select television system

- 1 Set the **SYSTEM** switch to the appropriate position according to your TV system. (Refer to the chart below.)

Major countries	Colour TV broadcast system	Switch position
China, Mongolia	PAL D/K	K
Russia	SECAM D/K	
Hong Kong	PAL I	I

Notes:

- If no colours appear on the screen when using a multi-system television with its system select switch set to AUTO, change the switch position to correspond to the recorder's RF system select switch (K or I).
- For more information on multi-system compatibility. [p.25](#)

Installations (cont'd)

Setting the video channel

To watch videos on your TV, it must be set to the same UHF channel as the video cassette recorder. This channel is used as the video channel.

This video cassette recorder has been preset to UHF channel E36.

Note:

- When you have connected the VIDEO/AUDIO output terminals of this video cassette recorder to your TV's VIDEO/AUDIO input terminals (connection B of the "Connections" section), setting the video channel is not necessary. In this case, simply set the TV's TV/VCR switch to VCR.

- 1 Turn the video cassette recorder's power on.
- 2 Set the TEST switch to "ON".
- 3 Turn on the TV and set it to UHF channel E36, and fine-adjust it until you can see the two vertical white bars on the screen most clearly.

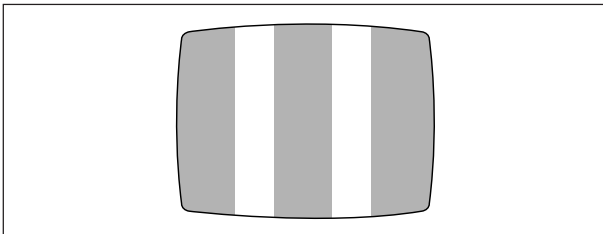

If UHF channel E36 is being used for broadcasting in your area:

Adjust the TV's channel selector a little at a time until the TV screen is blank (set it towards a higher or lower channel). Adjust the Channel adjustment screw on the rear panel of the video cassette recorder a little at a time until the two vertical white bars appear on the TV screen.

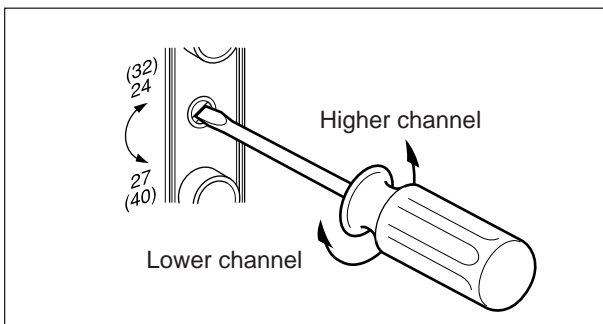

- 4 Reset the TEST switch to "OFF".

IMPORTANT:

To operate the recorder with your TV using an RF connection, it is always necessary to set your TV's channel to VIDEO CHANNEL. With an AV connection, set the TV to the VIDEO (or AV) mode.

Setting the On-screen

You can choose whether or not to have various operational indicators appear on screen, by setting this function "ON" or "OFF". Messages appear in the language you select.

- 1 Press OPERATE button to turn on the recorder.

- 2 Press OSD \oplus button.

- The Language screen appears. Place the pointer next to the language of your choice by pressing TV PROG. $\blacktriangle/\blacktriangledown$ button, then press OK button on the remote control to enter your selection.

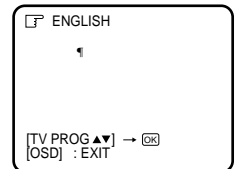

- 3 The pointer should already be next to "O.S.D.".
 - If not, press TV PROG. $\blacktriangle/\blacktriangledown$ button to place it there.

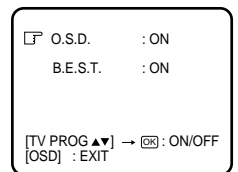

- 4 The default setting is "ON", so if you want on-screen displays, leave the setting as is and go to step 5.

- If you don't want the displays to appear, press OK button to set "O.S.D." to "OFF".

- 5 Press OSD \oplus button to close mode select screen.

On-Screen Displays

- 1 Channel position number/Aux. indicator (AUX)
- 2 Clock display
- 3 Current day/month/year
- 4 Type of broadcast
- 5 Tape position indicator
- 6 Audio mode displays
- 7 Operation mode indicators
- 8 Tape speed SP/LP/EP
- 9 Colour System indicator
- 10 Cassette loaded mark
- 11 B.E.S.T. indicator
- 12 Tape direction
- 13 Counter display (including Counter Memory indicator)
- 14 INDEX MARK/ERASE indicator

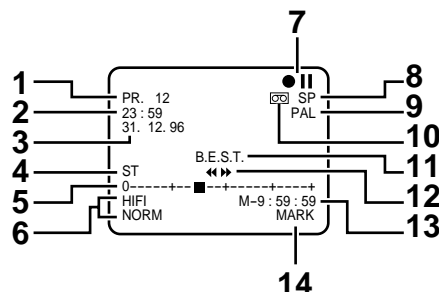

Setting the Clock

Since your video recorder bases all of its timer recording start and stop “decisions” on the time kept by its built-in clock, accurate setting of this clock is crucial for proper timer recording results. Each entry must be made within 10 seconds of the previous entry.

Use the buttons on the remote control for this procedure.

- 1 Press OPERATE button to turn on the recorder.
- 2 Press CLOCK button to access mode select screen.
- 3 Press TV PROG. ▲/▼ button to place the pointer next to “CLOCK SET”, then press OK button.
 - The Clock Set screen appears.
- 4 Use NUMBER button “1 (▲)” or “4 (▼)” to set the time.
 - Press and hold either button to delay or advance the time by 30 minutes.
- 5 Use NUMBER button “2 (▲)” or “5 (▼)” to set the date.
 - Press and hold either button to change the date by 15 days.
- 6 Use NUMBER button “3 (▲)” or “6 (▼)” to set the year.
- 7 Press CLOCK button to return to normal screen.

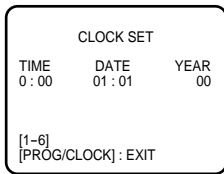
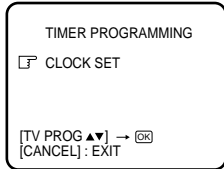

To Make Corrections

Perform steps 1 to 3 to call up the Clock Set screen, use NUMBER buttons “1” to “6” to make the correction, then press CLOCK button.

Note:

- If, in step 7, the year digits are automatically cleared, it is possible that you have input 29th February for a non-leap year. Input the correct data.

Power failure indicator

The clock resets to “-:-” when there has been a power failure. Reset the time to return the clock display to normal.

Setting the Tuner

Your recorder needs to memorise all necessary stations in channel positions in order to record TV programmes. Once stored, you can call them up with the TV PROG. ▲/▼ button without going through any vacant channels. Use the buttons on the recorder for this procedure.

- 1 Press OPERATE button to turn on the recorder.
 - Be sure to select the AUTO mode by pressing the COLOUR SYSTEM button.
- 2 Press and hold CHSET button for more than 2 seconds.
 - The Channel Set Mode Select screen appears.
- 3 Press TV PROG. ▲/▼ button to place the pointer next to “SEARCH/STORE”, then press OK button.
 - The Band Select screen appears.
- 4 Press TV PROG. ▲/▼ button to place the pointer next to the band of your choice, then press OK button to initiate Auto Channel Search.

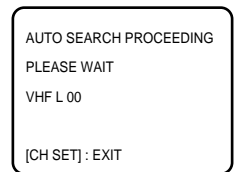
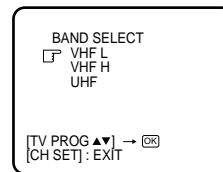
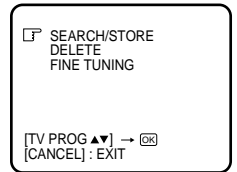

- 5 The right screen appears when a station is detected.
 - To store the detected station, place the pointer next to “STORE” by pressing TV PROG. ▲/▼ button, then press OK button.
 - If you don't want to store the station, press TV PROG. ▲/▼ button to place the pointer next to “CONTINUE”, then press OK button. Auto Channel Search will start resume.
 - The blueback screen and the TV picture currently being broadcast appear alternately for 8 seconds each.



- 6 Press TV PROG. ▲/▼ button until an open position in which you want to store a channel appears, then press OK button.

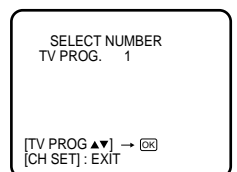

- 7 If fine tuning is not necessary, simply press STORE button.

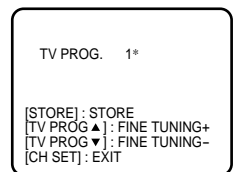

- For fine tuning adjustment, press TV PROG. ▲/▼ button until the picture becomes clearer, then press STORE button.

- To continue Auto Channel Search, press TV PROG. ▲/▼ button to select “CONTINUE”, then press OK button. Repeat steps 5 to 7 as necessary.

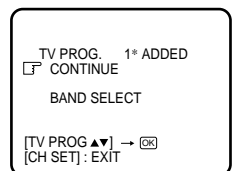

- To set channels for other bands, press TV PROG. ▲/▼ button to select “BAND SELECT”, then press OK button to go back to the Band Select screen. Repeat steps 4 to 7.

- 8 Press CH SET to return to normal screen.

Setting the Tuner (cont'd)

Delete A Stored Channel

- 1 Press OPERATE button to turn on the recorder.
- 2 Press and hold CH SET button for more than 2 seconds.
 - The Channel Set Mode Select screen appears.

- 3 Press TV PROG. ▲/▼ button to place the pointer next to "DELETED", then press OK button.

- 4 Press TV PROG. ▲/▼ button until the position number of the channel you wish to delete appears.

- If the on-screen display is hard to read, refer to the recorder's display panel.

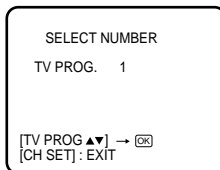

- 5 Press OK button twice.

- The screen shows the selected channel has been deleted.
- To delete another channel, press OK button again, then repeat steps 4 to 5.



- 6 Press CH SET button to return to normal screen.

Note:

- If you skipped a channel by mistake, perform steps 1 to 8 on page 9 to re-store it.

Fine-tuning channels already stored

- 1 Press OPERATE button to turn on the recorder.
- 2 Press and hold CH SET button for more than 2 seconds.
 - The Channel Set Mode Select screen appears.

- 3 Press TV PROG. ▲/▼ button to place the pointer next to "FINE TUNING", then press OK button.

- 4 Press TV PROG. ▲/▼ button so that the position number of the channel you want to fine-tune appears, then press OK button.

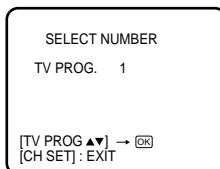

- 5 Press TV PROG. ▲/▼ button until the picture becomes clearer, then press STORE button.

- To fine-tune another channel, press OK button and repeat steps 4 to 5.

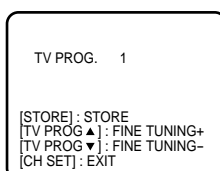

- 6 Press CH SET button to return to normal screen.

10

The Video Cassette

Inserting a cassette

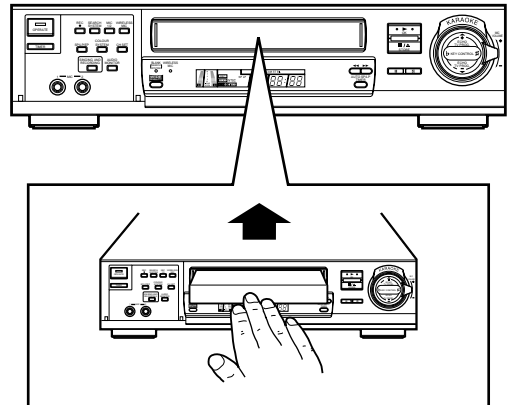

- Insert a cassette as shown and push it gently into the video cassette recorder.

The video cassette recorder turns on automatically and the cassette will be loaded.

- Press the Stop/Eject ■/▲ button to eject a video tape. During playback or recording, press the Stop/Eject ■/▲ button twice (once to stop the tape and once more to eject it).

Notes:

- If the video cassette's safety tab has been removed, playback will start automatically when the cassette is inserted.
- A cassette can also be ejected when the power is off.
- The cassette loaded mark blinks while the cassette is ejected.

Special note on video cassettes

To prevent accidental recording on a recorded cassette, remove its safety tab. To record on it later, cover the hole with adhesive tape.

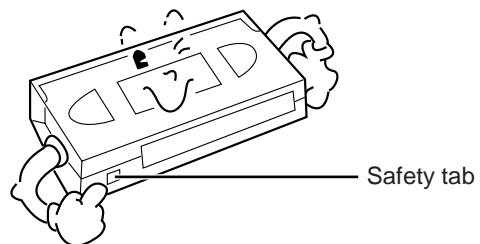

To watch a compact VHS tape

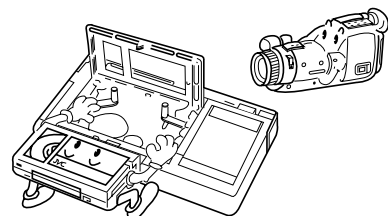

Compact VHS camcorder recordings can be played on your video recorder. Place the recorded cassette into a Cassette Adapter and it can be used like any full-sized VHS cassette.

B.E.S.T. Picture System

The B.E.S.T. (Biconditional Equalized Signal Tracking) system checks the condition of the tape in use during recording and playback, and compensates to provide the highest-possible recording and playback pictures. The default setting for both recording and playback is "ON".

Recording

1 Insert a cassette with the record safety tab intact.

- The recorder power comes on automatically.

2 Press OSD  button and the language screen appears. (To change the language,  p.8) Press OK button.

3 The default setting is "ON".

- If this is the case, go to step 4. If not, press TV PROG.  button to place the pointer next to "B.E.S.T.", then press OK button to set to "ON".

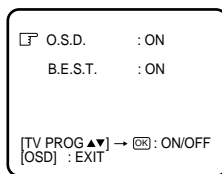

4 Press OSD  button to close mode select screen.

5 Press and hold Record  button and Play  button on the remote, or press Record  button on the recorder.



- The recorder spends approximately 7 seconds assessing the condition of the tape, then begins recording.
- When the "B.E.S.T." indicator begins blinking, that means adjustment is complete.





Notes:

- The B.E.S.T. system works for SP, LP (or EP) modes only after a tape has been inserted and the Record mode is first initiated. It does not work during recording.
- In the case of timer recording, the B.E.S.T. system works before recording is initiated.
- Once the cassette is ejected, the B.E.S.T. data is cancelled. The next time the cassette is used for recording, B.E.S.T. is re-performed.

ATTENTION:

Since the B.E.S.T. system works before recording actually starts, there is a delay of approximately 7 seconds after Record  and Play  buttons on the remote are pressed, or Record  button on the recorder is pressed. To make sure you record the desired scene or programme in its entirety, first perform the following steps:

- 1 Press and hold Pause/Still  and Record  buttons to engage the Record Pause mode.
 - The recorder then automatically check the condition of the tape and, after approximately 7 seconds, re-enters Record Pause.
- 2 Press Play  button to start recording.
 - If you want to bypass the B.E.S.T. system and begin recording immediately, set "B.E.S.T." to "OFF" in step 3 above.

Playback

The recorder assesses the quality of the tape once you initiate playback.

When watching a tape recorded with "B.E.S.T." set to "ON", it is recommended that you leave B.E.S.T. on during playback as well.

1 Press Play  button to start playback.

- The recorder adjusts the playback picture quality based on the quality of the tape in use.
- B.E.S.T. is active during Auto Tracking. "B.E.S.T." appears blinking on the screen.



Notes:

- When watching a rental tape, or one recorded on another video recorder, set B.E.S.T. to your preference by performing steps 2 through 4.
- "B.E.S.T." only appears at the beginning of automatic tracking. Even though it doesn't appear after that, the B.E.S.T. function is operative.

Playback

Basic operations

Turn on the TV: Select VIDEO channel (or AV mode).

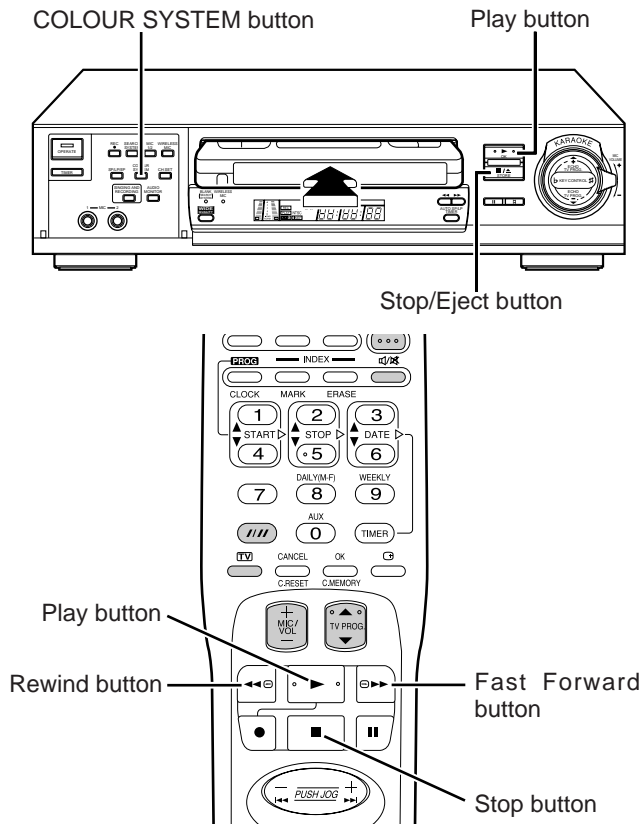

Variable-speed/High-speed search, still playback/frame advance/forward slow motion

During Playback:

- Press PUSH JOG ◀◀ or ▶▶ button for variable-speed search.
- The more times the button is pressed, the faster the playback picture will move.
- To decrease speed, press the button for the opposite direction.

During Playback:

- Press Fast Forward ▶▶ button for high-speed forward search, or Rewind ◀◀ button for high-speed reverse search.
- For short searches, keep Fast Forward ▶▶ button or Rewind ◀◀ button pressed for more than 2 seconds. When released, normal playback will continue.
- Press Pause/Still || button on the remote control to view a still picture.
- Press again to advance the picture frame by frame.
- Press Pause/Still || button on the remote control for 2 seconds for slow motion.

During Still:

- For frame-by-frame playback in the forward or reverse direction, press PUSH JOG ◀◀ or ▶▶ button in the corresponding direction.

Manual tracking

Your video recorder is equipped with automatic tracking control. If you wish to adjust tracking manually, you can override this function.

During Playback:

- 1 Press Auto tracking /// button on the remote control.
 - 2 Press TV PROG. ▲/▼ button to adjust tracking.
- Press Auto tracking /// button to return to automatic tracking.

During Slow:

- 1 Simply press TV PROG. ▲/▼ button to adjust tracking.

Notes:

- The recorder automatically stops when still continues for more than 5 minutes.
- If the still picture is unstable, use the TV PROG. ▲/▼ button to correct the picture.
- During search playback, some noise bars will appear.
- When playing back LP recordings in the search, still, or frame-by-frame playback mode, the picture will be distorted, and there will be a loss of colour.
- There is no audio during search, slow, still, or frame-by-frame playback.
- When a new tape is inserted, the recorder enters the automatic tracking mode automatically.

IMPORTANT:

- Normally set colour system detection to "AUTO" by pressing the COLOUR SYSTEM button. If a tape is not played back correctly, try manual setting, p.25.
- If viewing an NTSC or MESECAM tape, set the COLOUR SYSTEM button to match the type of TV being used, p.26.
- For more information on multi-system compatibility, p.26.

1 Load a cassette.

- The recorder power will come on automatically.
- The counter will reset to "0:00:00" automatically.
- If the safety tab on the cassette is removed, playback will start automatically.

2 Press Play ► button to start playback.

- "B.E.S.T." appears blinking in the on-screen for 5 seconds. (p.11)

3 Press Stop ■ button to stop playback.

- To rewind the tape, press Rewind ◀◀ button.
- To fast-forward the tape, press Fast Forward ▶▶ button.
- To stop rewind or fast-forward, press Stop ■ button.

4 Press Stop/Eject ■/▲ button on the recorder to eject the tape.

Playback (cont'd)

Wide quality

Use this function to improve image contrast which tends to degrade especially with wide-screen TVs.

During Playback:

- 1 Press **WIDE QUALITY** button on the recorder.
 - The button will light in "green".
 - Pressing the button again turns off the light.
 - Turn on/off the light according to the type of playback picture you want.
 - The setting will remain effective even though you turn on/off the recorder.
 - This function is also effective with large-screen 4:3 aspect ratio TVs as well.

Index search

Your recorder automatically marks index codes at the beginning of each recording. This function gives you quick access to any one of 99 index codes in either direction.

During Stop:

- 1 Press **SEARCH SYSTEM** to make the **BLANK** indicator disappear on the front panel.
- 2 Press **◀◀** or **▶▶** button.
 - **◀◀ 1** or **▶▶ 1** will be displayed on the screen and search will begin in the corresponding direction.
- 3 If you wish to access index codes 2 through 99, press **◀◀** or **▶▶** button repeatedly until the correct index number is displayed.

Example:

To locate the beginning of B from the current position, press **◀◀** button twice.
 To locate the beginning of D from the current position, press **▶▶** button once.

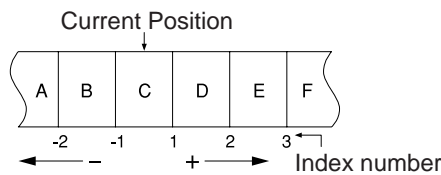

- When the specified index code is found, playback will start automatically.

To mark an index code manually

During Playback or Still:

- 1 Press **INDEX MARK** button on the remote control.
 - The recorder will mark an index code at that location.

To erase an index code

During Playback or Still:

- 1 Press **INDEX ERASE** button on the remote control.
 - The recorder will fast-forward to the nearest index code and erase it. Playback continues after the index code is erased.

Note:

- If the tape's safety tab has been removed, index codes cannot be marked or erased.

Counter memory

During Playback:

- 1 Press **C.RESET** button at a point you wish to locate later.
 - The counter will read "0:00:00".
- 2 Press **C.MEMORY** button.
 - The **M** indicator will light on the display panel.
- 3 When you wish to return to that point, press **Stop** button and then **Rewind** **◀◀** button.
 - The tape will rewind and stop at about "0:00:00" automatically.
- 4 To cancel the Counter Memory mode, press **C. MEMORY** button again.

Next function memory

Your recorder can memorise what to do after rewind.

During Stop:

- For automatic power off after the tape is rewound
 - 1 Press **Rewind** **◀◀** button.
 - 2 Press **OPERATE** button within 2 seconds.

Repeat playback

During Playback:

- 1 Press **Play** **▶** button for more than 5 seconds, and release.
 - The **PLAY** indicator on the display panel will blink slowly.
 - The tape will be played all the way to the end, 20 times automatically, and then stop.
- 2 To stop playback at any time, press **Stop** button.

Soundtrack selection

During Playback:

Your video recorder is capable of recording three soundtracks (HIFI L, HIFI R and NORM) simultaneously, and playing back the selected soundtrack.

- Pressing **AUDIO MONITOR** changes the track:

Track (on display panel):	Use:
L + R	for Hi-Fi stereo tapes
L	for main audio of bilingual tapes
R	for sub audio of bilingual tapes
NORM	for audio-dubbed tapes
L + R + NORM	for audio-dubbed tapes

Note:

- Normally use the "L + R" position. Then Hi-Fi stereo tapes are played back in stereo, and tapes with normal audio only are played back automatically in the NORM mode.

Recording

Basic operations

Record button

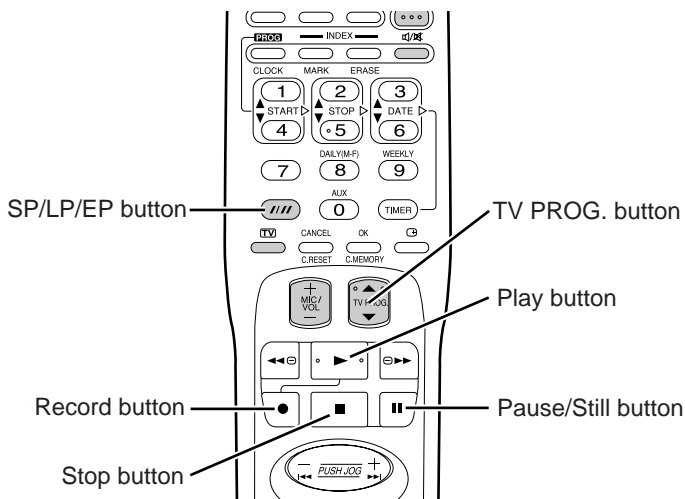
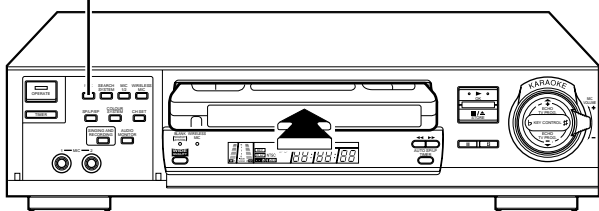

IMPORTANT:

- Press the COLOUR SYSTEM button so "AUTO" lights up on the on-screen display.
- For more information on multi-system compatibility, see p.25.

- 1 Load a cassette.
 - 2 Press TV PROG. ▲/▼ button or the NUMBER buttons to select the channel you wish to record.
 - 3 Press SP/LP/EP /// button to select the tape speed.
 - 4 Press Record ● and Play ► buttons on the remote control simultaneously.
- B.E.S.T. takes place at the beginning of both the first SP and the first LP (or EP) recording after inserting the cassette. (see p.11)
- 5 Press Pause/Still || button on the remote control to pause recording.
 - 6 Press Play ► button to resume recording.
 - 7 Press Stop ■ button to stop recording.

Instant timer recording (off timer)

You can start a recording and then set the recorder to shut off automatically after a set duration.

During record:

- 1 Press Record ● button on the recorder. "REC" indicator blinks and "0:30" indications appear, advising that power will switch off after 30 minutes.
- 2 Press Record ● button again to delay the off-time by 30-minute increments (up to 6 hours).

To watch another programme while recording

During record:

- 1 Use the channel controls on the TV to select the other channel you wish to view.

- The programme selected with the TV's channel controls will appear on the TV screen while the one selected with the video recorder's channel controls will be recorded on the tape.

Notes:

- To start recording with the recorder's Record ● button, press it once on its own.
- After pause, when recording is resumed, a few frames recorded before the pause may be overlapped by the new recording. This is meant to reduce picture distortion and is not a malfunction.
- The recorder automatically stops when Record Pause mode continues for more than 5 minutes.
- If Record does not work, check to see if the cassette's safety tab has been removed.
- The channel cannot be changed while recording is in progress. To change the channel, engage the Record Pause mode, then change the channel using the remote control.
- The recorder automatically rewinds when the end of the tape is reached during recording.
- The recorder automatically places an index code on the tape every time recording begins. For information on the Index Search function. (see p.13)

Recording (cont'd)

Elapsed recording time indication

When you need to know the exact time of a recording.

1 Press **C.RESET** button before starting recording or playback.

■ The counter will be reset to "0:00:00" and show the exact elapsed time as the tape runs.

Usable cassettes and their recording times

This video recorder can record on regular VHS and Super VHS cassettes. However, it will record and play back regular VHS video signals only. It is not possible to play back a recorded Super VHS tape.

Type of Cassette	Recording/Playback Time (minutes)		Recording/Playback System
	SP Speed	LP Speed	
E-240	240	480	PAL/MESECAM
E-180	180	360	PAL/MESECAM
E-120	120	240	PAL/MESECAM
E-90	90	180	PAL/MESECAM
E-60	60	120	PAL/MESECAM
E-30	30	60	PAL/MESECAM

Type of Cassette	Recording/Playback Time (minutes)		Recording/Playback System
	SP Speed	EP Speed	
T-160	160	480	NTSC
T-120	120	360	NTSC
T-90	90	270	NTSC
T-60	60	180	NTSC
T-30	30	90	NTSC

Timer Recording

Before performing the following steps:

- Insert a cassette with the safety tab in place. The recorder will come on automatically.
- Turn on the TV and select the VIDEO channel (or AV mode).
- Select the appropriate colour system by pressing the COLOUR SYSTEM button. (p.25)

COLOUR SYSTEM button

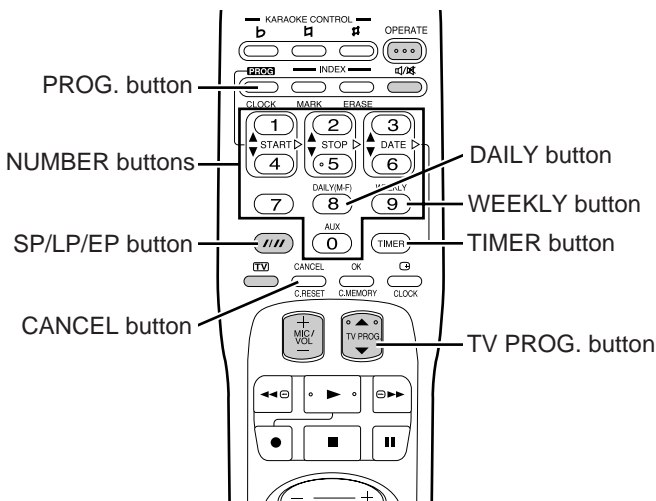
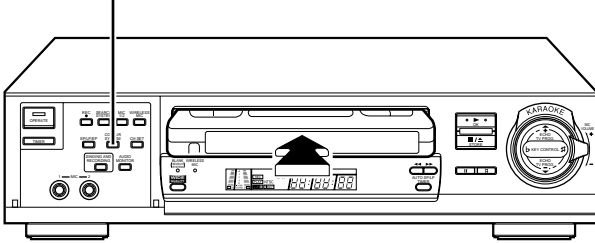

1 Press **PROG.** button to access mode select screen.

2 Press **TV PROG. ▲/▼** button to place the pointer next to "TIMER PROGRAMMING", then press **OK** button.

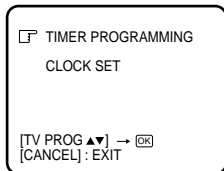

3 Press **NUMBER** button "1 (▲)" or "4 (▼)" to enter the time you want recording to start.

- Press and hold either button to delay or advance the time by 30 minutes.
- If the Programme is already used, press **PROG.** button until a vacant Programming screen appears.

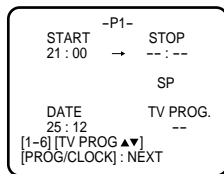

4 Press **NUMBER** button "2 (▲)" or "5 (▼)" to enter the time you want recording to stop.

- Press and hold either button to delay or advance the time by 30 minutes.

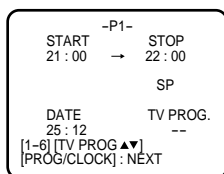

5 Press **NUMBER** button "3 (▲)" or "6 (▼)" to enter the date.

6 Press **TV PROG. ▲/▼** button to select the channel you wish to record.

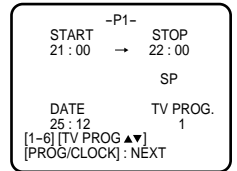

7 Press **SP/LP/EP** button to set the tape speed.

- For each additional programme, press **PROG.** and repeat steps 3 to 7.

8 Press **PROG.** button as many times as necessary to return to normal screen.

9 Press **TIMER** button to engage recorder's timer mode.

■ To Timer-Record Weekly Or Daily Serials...

...anytime during steps 3 through 7, press **WEEKLY** (NUMBER button "9") for weekly serials or **DAILY** (NUMBER button "8") for daily serials (Monday to Friday).

Notes:

- You can programme this recorder to timer-record as many as 8 programmes. To record the extra programme, you must first cancel any unnecessary programmes. (Check And Cancel Programmes p.17)
- For safety, your recorder disables all other functions while in the Timer mode. If you want to use the recorder but its Timer mode is engaged, press **TIMER** button and all other functions are operable. To re-engage the timer, press **TIMER** button.
- In case of a power failure after programming, the recorder's memory backup keeps your selections for 18 hours.
- Backup time becomes shorter as the unit's internal parts becomes old. When this occurs, please consult your nearby JVC dealer.

Timer Recording (cont'd)

Check And Cancel Programmes

1 Perform steps 1 and 2 of Timer Recording to call up the Timer Programming screen.

- If the recorder is in the Timer mode, first press TIMER button to exit the mode.

2 Press PROG. button until the programme you wish to call up appears.

- Each time you press PROG. button the next programme's information appears up to "P8" (Programme 8).
- If you want to make a correction, use NUMBER buttons "1" to "6" and TV PROG. ▲/▼ button.
- If you want to cancel a programme, press CANCEL button.

3 Press PROG. button as many times as necessary to return to normal screen.

- Press TIMER button to engage the recorder's Timer mode.

Auto SP/LP Timer

If, when recording in SP mode, there is not enough tape to record the entire programme, the recorder automatically switches to LP mode (with PAL broadcasts) or EP mode (with NTSC broadcasts) to allow complete recorder.

Press AUTO SP/LP TIMER button on the recorder front panel. The button lights "orange".

Example:

Recording a PAL-broadcast programme of 210 minutes in length onto a 180-minute tape

Approximately 150 minutes Approximately 60 minutes

SP mode	LP mode
---------	---------

Total 210 minutes

Make sure you press AUTO SP/LP TIMER button before performing timer programming.

Notes:

- The Auto SP/LP Timer feature is not available during ITR (Instant Timer Recording), and the feature will not work properly with any tapes longer than E-180 as well as some tapes of shorter lengths.
- Even if, in step 1, you press AUTO SP/LP TIMER button and it lights "orange", that doesn't mean that the recorder will automatically change from SP to LP mode during the course of the recording. Watch the tape later to confirm.
- If you have programmed the recorder to timer-record 2 or more programs, the second programme and those thereafter may not fit on the tape if you engage the Auto SP/LP Timer mode. In this case, make sure the mode is not engaged, then set the tape speed manually during timer programming.
- There may be some noise at the point on the tape where the recorder switches from SP to LP (or EP) mode.

Karaoke

Connecting to Hi-Fi stereo system

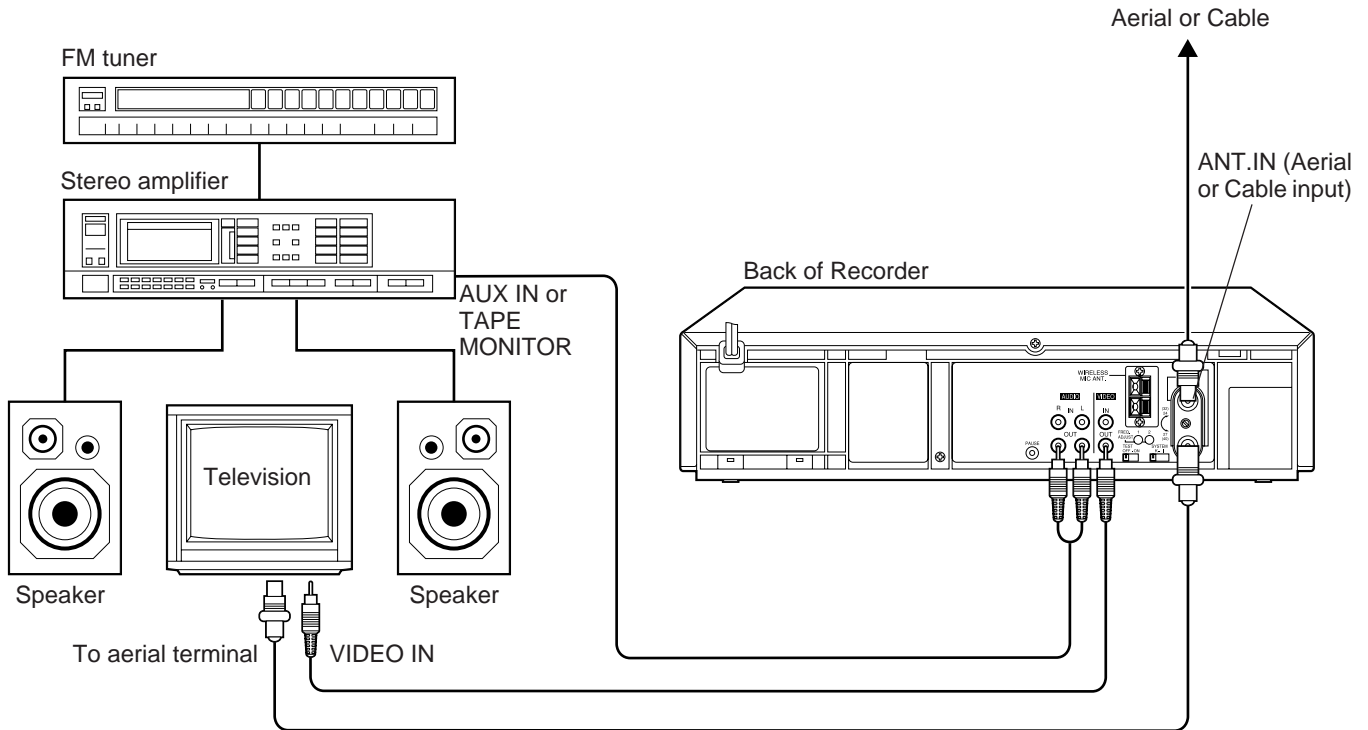

If you have a Hi-Fi stereo system, you can connect your video recorder to it so that the sound can be heard through your Hi-Fi system. Please make these additional connections:

Hi-Fi audio connection

- 1 Connect the AUDIO IN “L” and “R” connectors of the recorder to the recording output terminals of the amplifier.
- 2 Connect the AUDIO OUT “L” and “R” connectors of the recorder to the AUX IN or TAPE MONITOR terminals of the amplifier.

Notes:

- Make sure “L” and “R” are correct when connecting the audio input and output connectors of the recorder to a stereo amplifier.
- If stereo or bilingual TV broadcasts are receivable in your area, this recorder can record them independently of the TV set and play them back through the connected audio system.
- When listening to sound from the connected stereo system, turn down the sound volume of the TV completely.

CAUTION:

- This recorder has a dynamic range of more than 90 dB with regards to its Hi-Fi audio capability. It is recommended that you check the maximum level if you are going to listen to the Hi-Fi audio signals through a stereo amplifier. A sudden surge in speaker input may cause speaker damage.
- Some speakers and televisions are specialty shielded to prevent television interference. If both are of the non-shielded type, do not place the speakers adjacent to the TV set, otherwise the video playback picture may be adversely affected.

Karaoke (cont'd)

Microphone

Two microphones are provided. One can be used as a wireless microphone, another one can be used as wireless or wired microphone.

How To Use

To use as a wired microphone

- 1 Insert the connector cable to the end of the Microphone as illustrated and turn it clockwise to fix.
- 2 Set the MIC select switch to "WD. (Wired)".

To use as a wireless microphone

- 1 Insert the antenna cable to the end of the microphone as illustrated and turn it clockwise to fix.
- 2 Set the MIC select switch to "WL. (Wireless)".

ATTENTION:

When you are not using the microphone, it is recommended to set the MIC select switch to OFF: otherwise the batteries will discharge even when not in use.

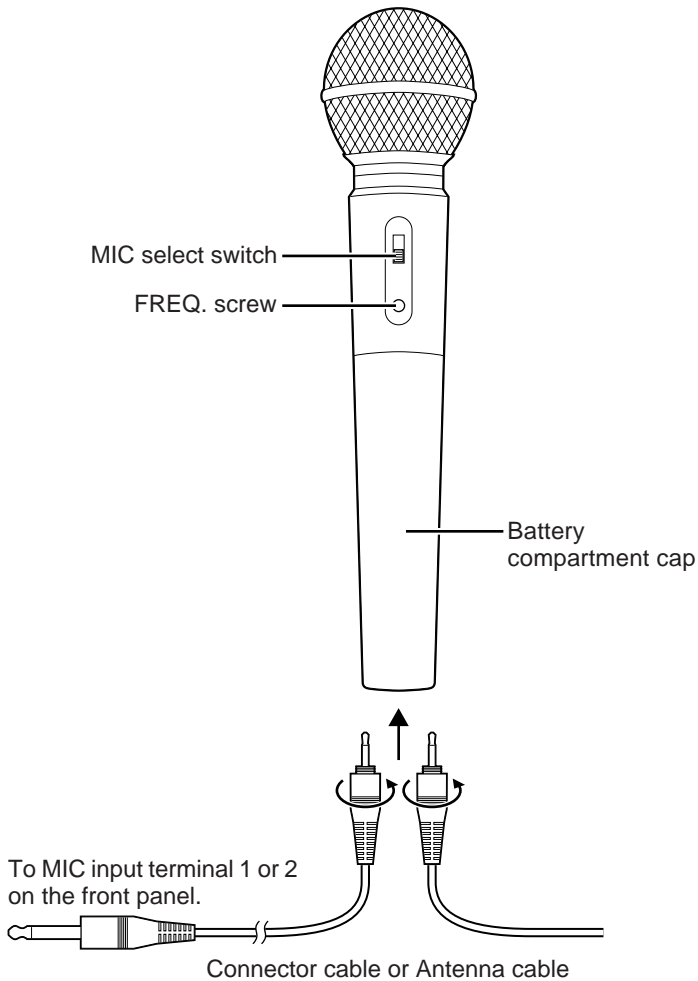

Installing Batteries

- 1 Unscrew and remove the battery compartment cap.
- 2 Insert 2 "AA/UM-3"-size batteries (provided) in the correct directions.
- 3 Screw the cap back on.

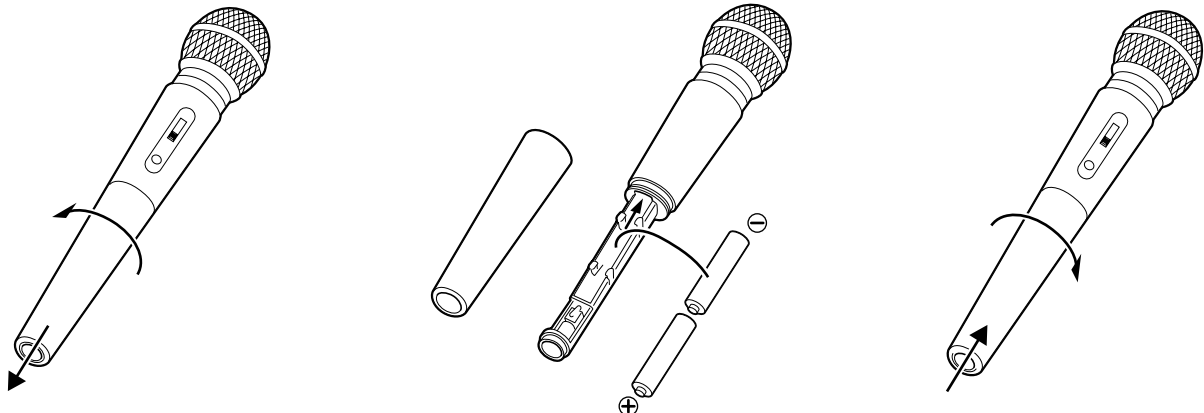

Karaoke (cont'd)

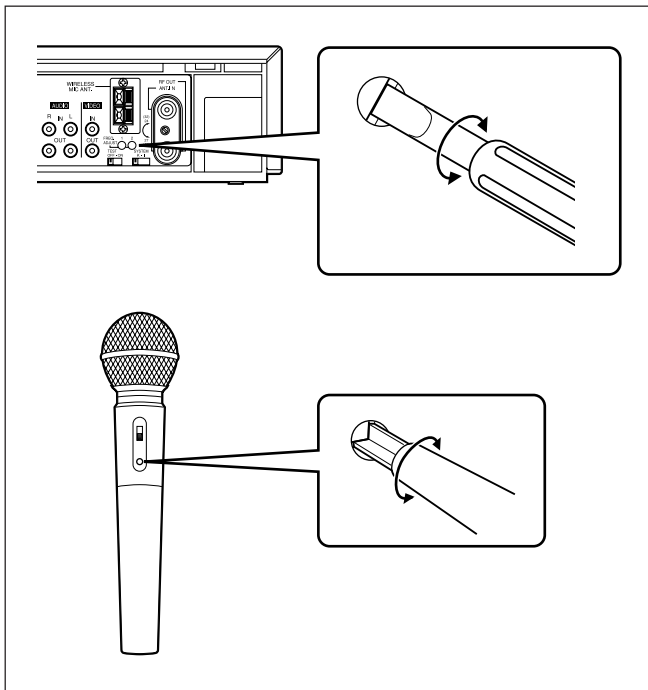

If there is interference when using the microphone

Follow the steps below to re-adjust the frequency of the microphone and your recorder.

Preparation

1. Turn on your TV and recorder.
2. Select the TV's video channel.
3. Select the external input channel by pressing the TV PROG. buttons.
 - "AU" will appear on the recorder's display panel.
4. Press the WIRELESS MIC button on the recorder's front panel.
 - The WIRELESS MIC indicator will light.
5. Set the microphone's MIC select switch to "WL. (Wireless)".

Operation

1. Turn tightly the **FREQ.** screw on the recorder's rear panel in either direction with the provided screwdriver (attached at the rear of the battery compartment).
2. While speaking into the microphone continuously. Turn the microphone's **FREQ.** screw with the provided screwdriver in the same direction as in step 1. until your voice can be clearly heard from the TV's speaker.

Check

1. First set the microphone's MIC select switch to "OFF". and set the switch to "WL. (Wireless)".
2. Speak into the microphone and check if your voice can be heard from the TV's speaker.
 - If your voice cannot be heard. Try again steps 1 and 2 of "Operation".

The Karaoke Control Centre on the recorder's front panel gives you direct access song search, and sound volume/echo control. The provided microphone can also be used as a wireless microphone.

Preparation

To use the microphone as a wireless microphone

You need to connect the provided FM feeder cable to the recorder.

- 1 While you press the lever, connectors, insert the provided FM feeder cable into the connectors.

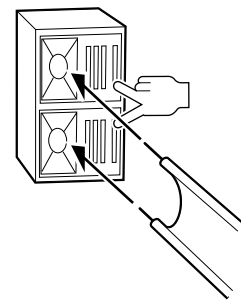

- 2 Release the lever.

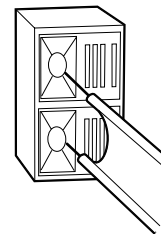

- 3 Hang the FM feeder cable on the wall behind the recorder so that the cable forms a "T".

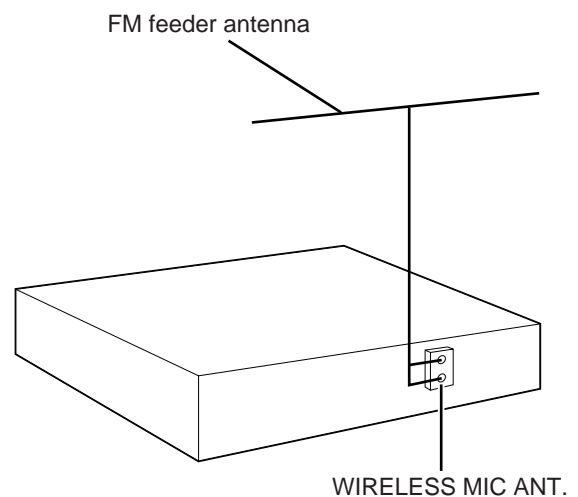

Karaoke (cont'd)

- 4 Follow steps 1 and 2 of "To use as a wireless microphone". (p.19)
- 5 Press the recorder's WIRELESS MIC button to make the indicator light.

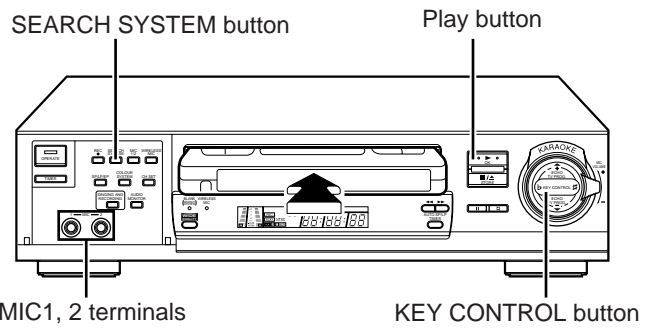
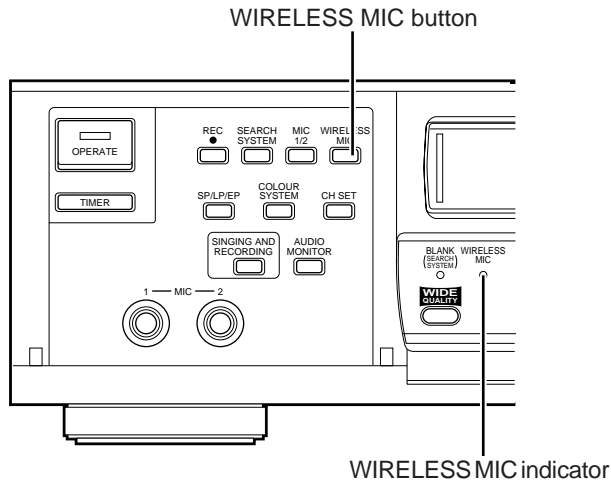

To use the microphone as a wired microphone

- 1 Follow steps 1 and 2 of "To use as a wired microphone". (p.19)
- 2 Connect the microphone to the recorder's front panel MIC1 or MIC2 terminal.

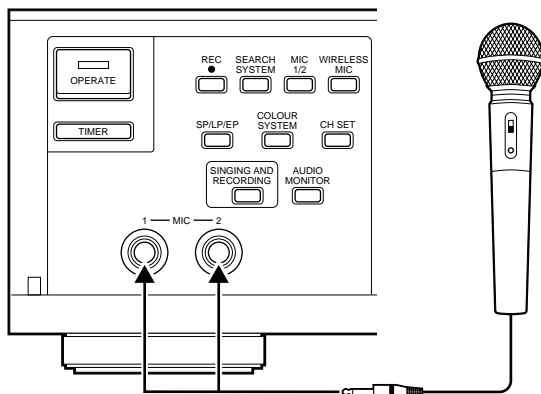

Notes:

- The maximum operating distance of the wireless microphone is about 10 m.
- You can use up to 4 microphones (2 wired and 2 wireless) at the same time with this recorder.

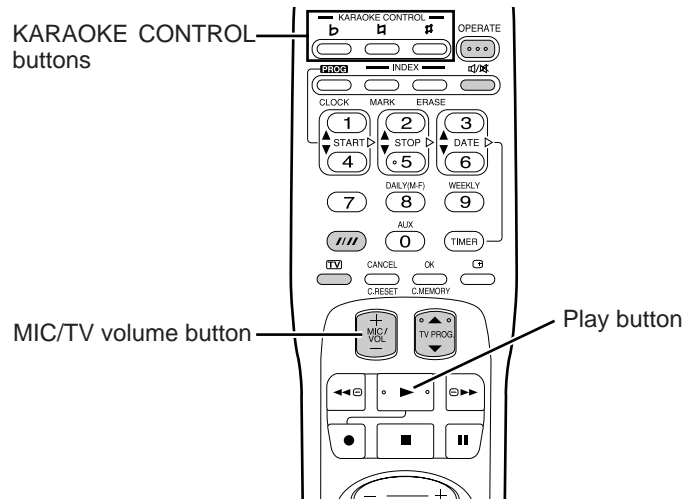

Basic operations

- 1 Turn on the TV and select VIDEO channel (or AV mode.)
- 2 Set the microphone's switch to "WD. (Wired)".
- 3 Insert a pre-recorded Karaoke tape.
 - If the safety tab on the cassette is removed, playback will start automatically.
- 4 Press Play ► button.
- 5 Start singing.

Karaoke (cont'd)

Key control

You can adjust the sound of your Karaoke tape to better match your voice.

- 1 To raise the key, press **#** button.
To lower the key, press **b** button.

- Every time the **#** (or **b**) button is pressed, the music's key is raised (or lowered) by one level. The key can be raised by a maximum of 6 levels, or lowered by a maximum of 6 levels.

Lower the key up to 6 levels
Raise the key up to 6 levels

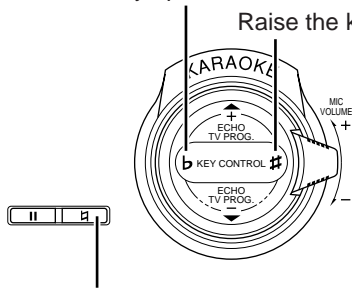

Go back to the original key

- 2 To go back to the original key, press **h** button.

Notes:

- Whenever you turn the unit on again or a karaoke tape is reloaded, the previously-set Key Control adjustment will be canceled.
- The Key Control function is also effective for TV broadcasts being received or other audio signals received via input connectors.

Echo control

You can add as much echo to your voice as you like.

- 1 Press **ECHO +** or **-** button during playback.

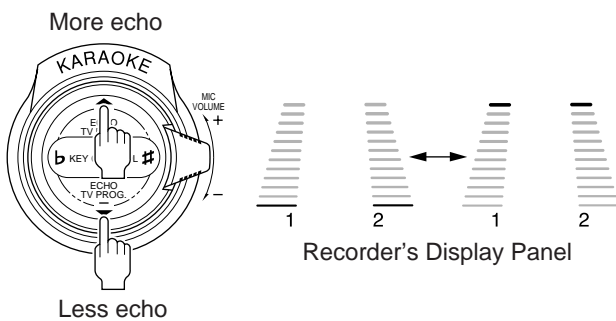

Less echo

- The same echo level is applied to both MIC1 and MIC2.

Volume adjustment

Adjust the microphone volume as necessary.

- 1 Turn the **MIC VOLUME** control up or down.

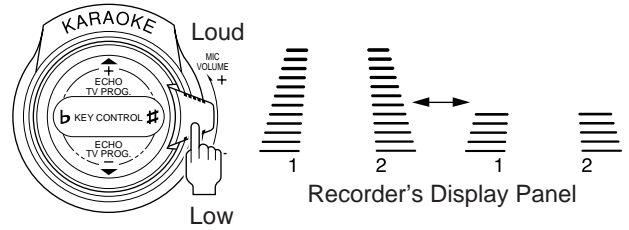

To adjust the volume of MIC1 and MIC2 respectively

- 1 Press **MIC1/2** button.

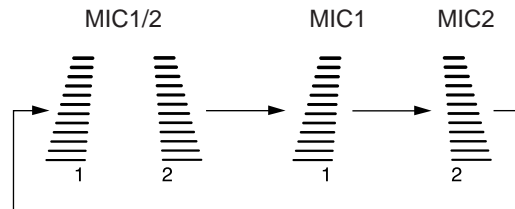

- Pressing **MIC1/2** button changes the recorder's display as illustrated above and the corresponding microphone volume level will be displayed.

- 2 While the corresponding microphone volume level is displayed, use the recorder's **MIC VOLUME** control to adjust the microphone volume.

- The display panel will automatically return to the current display after about 5 seconds.

Karaoke (cont'd)

Direct access song search (blank search)

This function gives you direct access to the start of the next tune to be sung by searching for the blank portion between tunes.

During Stop:

1 Press **SEARCH SYSTEM** button so that the **BLANK** indicator lights.

■ Pressing **SEARCH SYSTEM** button switches the Search system, **BLANK** or **INDEX**. (For **INDEX** search, see p.13)

2 Press **◀◀** or **▶▶** button.

■ "◀◀ 1" or "▶▶ 1" will appear on the screen.

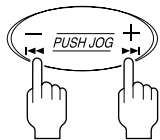

◀◀ 1 or ▶▶ 1

■ Specify the number of the song (up to ±99) you want to locate.

Example:

To locate the third song from the current position, press **▶▶** button three times.

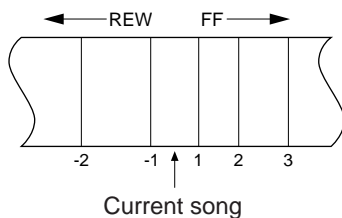

■ The tape will begin playing when the specified song is reached.

■ **BLANK SEARCH** does not work with a tape which has no signal on its normal soundtrack. Also, if the length of blank parts between tunes is shorter than 4 seconds, if the tune has a fade-out ending, or if the tape contains excessive noise signals, **BLANK SEARCH** may not work properly with that tape.

■ If you wish direct access song search with a tape that has blank parts between tunes shorter than 4 seconds, you can use **INDEX** search. (see p.13)

■ No sound outputs during **BLANK SEARCH** mode.

Singing and recording (SAR)

As you sing, this feature records your voice, together with the musical accompaniment being played back from the Hi-Fi tracks of a Karaoke tape, onto the normal (monaural) track of that tape. It's a convenient way to record your own singing and listen to it later.

To record your song

1 Insert a cassette with the song you want to sing. This cassette must have a safety tab, or a piece of adhesive covering the slot. (see p.10)

2 Search for the beginning of the song (see p.13), and play back the tape and then press **Pause/Still** button.

3 Press **SINGING AND RECORDING** button. The indicator changes as follows.

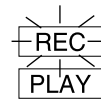

4 Press **Play** button and sing along to the tape playback sound.

■ Both your voice and the music are recorded on the tape's normal track.

5 When your song ends, press **Stop** button.

To replay what you've sung

1 **Rewind to the beginning of your song.**

■ Index Search makes finding songs easier. (see p.13)

2 Press **Play** button.

3 Press **AUDIO MONITOR** button on the recorder to choose the normal track.

■ "NORM" appears on the display panel.

■ Your voice and music can both be heard.

Notes:

- Do not use Singing and Recording (SAR) on a tape which only has a normal (monaural) soundtrack because this will erase the original sound on the tape.
- SAR cannot be done with a tape that has been recorded in NTSC EP speed.

Editing

Editing to/from another recorder

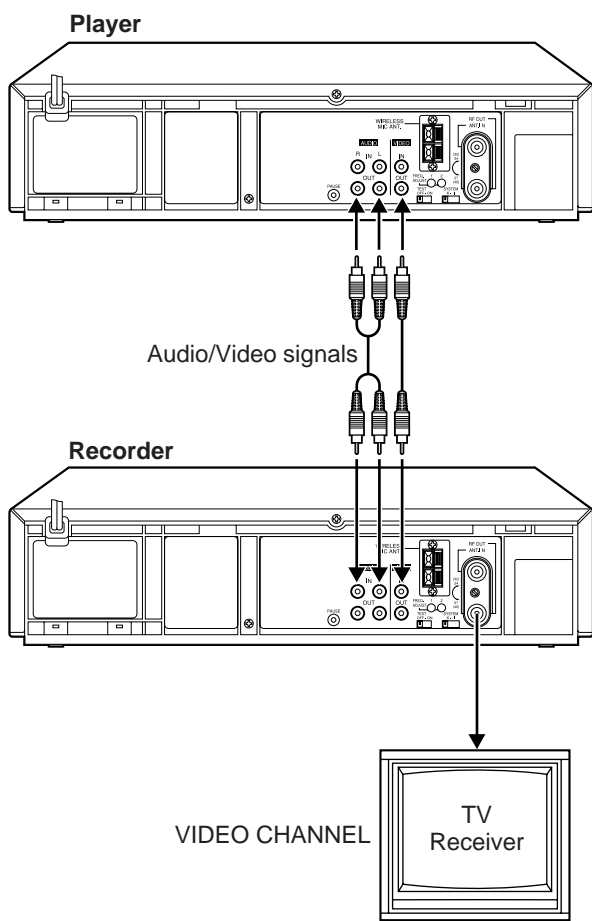

Preparation

Connect the player's AUDIO and VIDEO OUT connectors to the recorder's AUDIO and VIDEO IN connectors.

1 Select the recorder's external input mode.

- With this video recorder, press NUMBER button "0". "AU" will appear instead of a channel number.

2 Put the player in the Play mode.

3 Put the recorder in the Recorder mode.

Note:

- When you dub an NTSC tape using your recorder as the playback deck, select MANUAL NTSC (or 4.43) with the COLOUR SYSTEM button. (p.25)

Editing from a camcorder

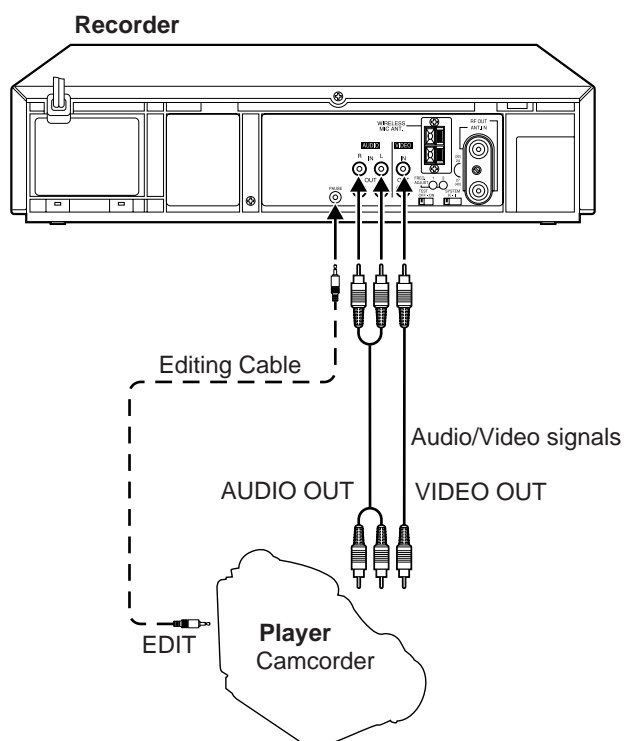

Preparation

Connect the camcorder's AUDIO and VIDEO OUT connectors to the recorder's AUDIO and VIDEO IN connectors.

1 Select the recorder's external input mode by pressing NUMBER button "0". "AU" will appear instead of a channel number.

2 Put the camcorder in the Play mode.

3 Put the recorder in the Record mode.

IMPORTANT:

- To edit, both the player and the recorder must be of the same colour system. Press your recorder's COLOUR SYSTEM button to select the appropriate colour system.
- PAL, SECAM and NTSC camcorders can be used as a player for editing.
- For more information on multi-system compatibility. (p.25)
- If the camcorder is equipped with the Master Edit Control system, you can control the recorder using the camcorder's controls. See the camcorder's instruction manual for operating procedure.

Information on Multi-System Compatibility

Setting of the colour system select buttons

Use the COLOUR SYSTEM button on the recorder's front panel to select the colour system. Pressing this button changes the mode as illustrated below. An indicator on the screen will show which mode is selected.

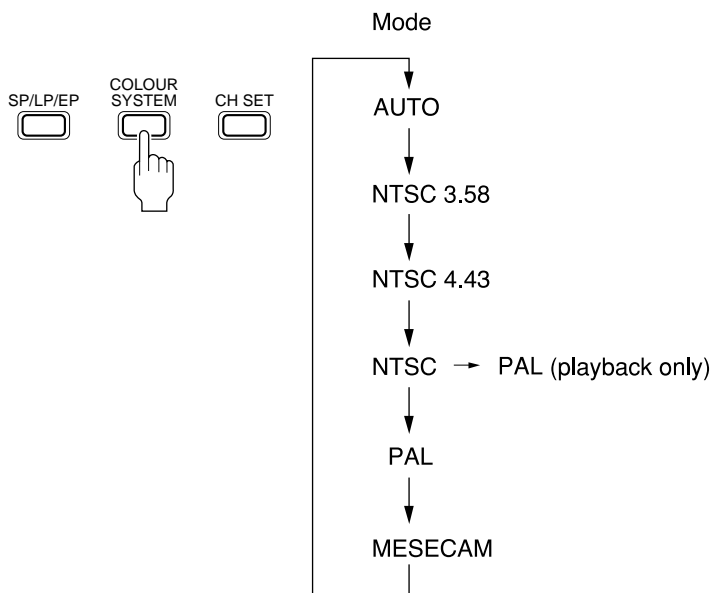

Mode Display	Description
AUTO (Colour Signal)	Usually set to this mode. This mode automatically detects PAL, NTSC, SECAM or MESECAM and adjusts to the colour system being recorded or played back. When it does not perform properly, set the colour system manually.
MANUAL (Colour Signal)	For recording, there is a choice of 4 selectable modes; PAL/MESECAM/NTSC/NTSC4.43. Select the mode that matches the colour signal being received. For playback, there is an additional mode which allows NTSC tapes to be played back and viewed on PAL TVs.

Notes:

- In the AUTO mode, NTSC signals will be automatically recorded as NTSC.
- SECAM signals will always be recorded as MESECAM. Select the AUTO or MANUAL MESECAM mode when recording SECAM signals.
- When playing back a SECAM tape, select the AUTO or the MANUAL MESECAM mode. The playback picture will always be mono chrome.

Off-air recording

The built-in multi-system tuner is capable of receiving D/K, I broadcasts.

TV system

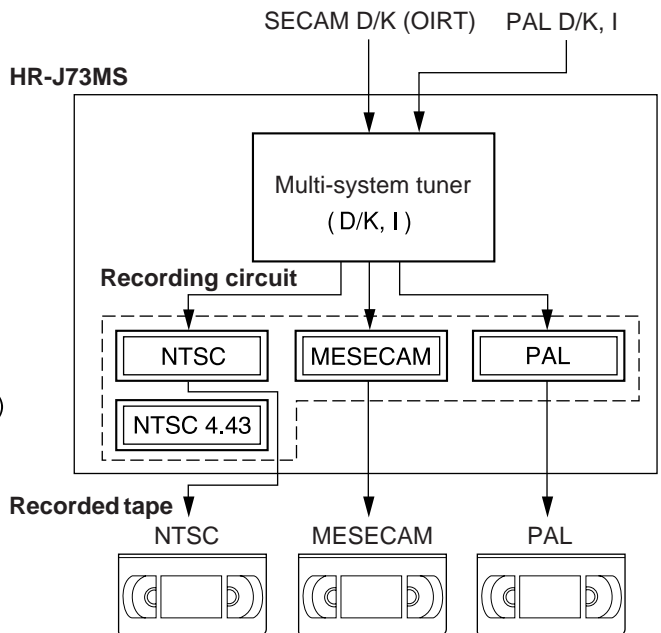

Note:

- This model does not operate in BRAZIL (PAL-M) or ARGENTINA (PAL-N).

Information on Multi-System Compatibility (cont'd)

Playback

This recorder can play back all 3 types of recorded tape.

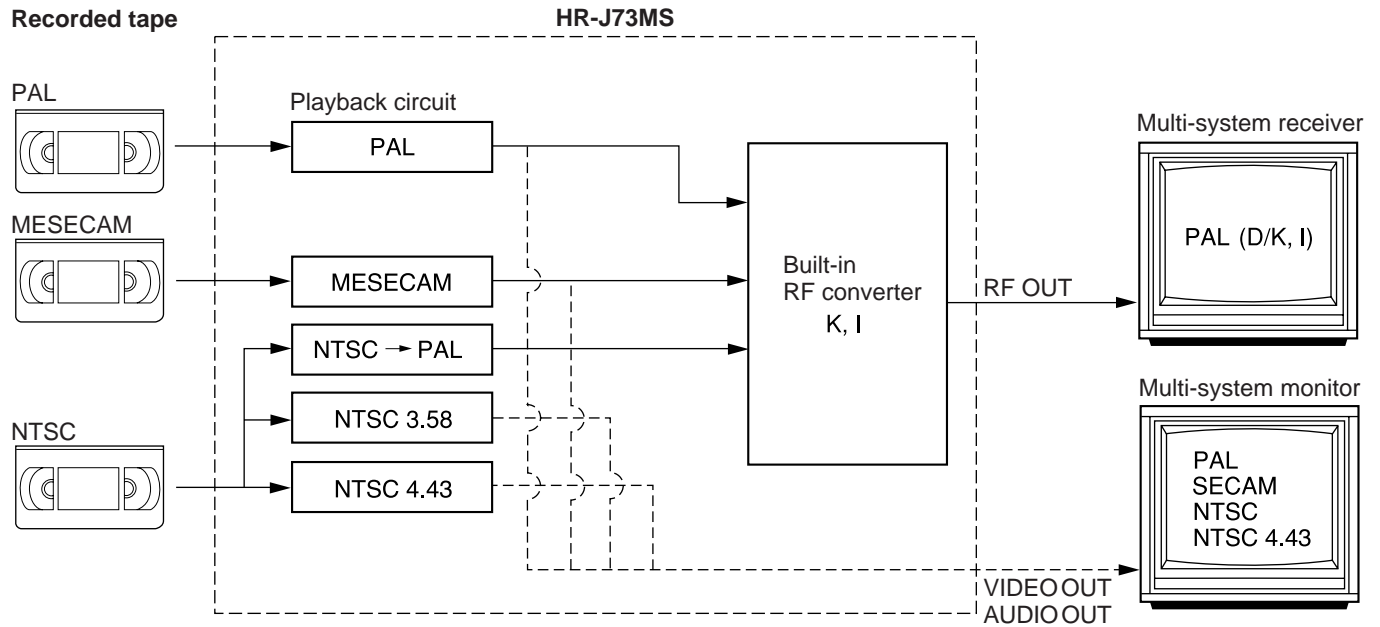

Notes:

When viewing NTSC tapes on a PAL TV set:

- The picture may shrink vertically with black bars appearing at the top and bottom of the screen. This is not a malfunction on the part of the video recorder nor the TV.
- The picture may roll up or down. This can be corrected using the V-HOLD control found on most TVs. (This cannot be corrected if the TV does not have a V-HOLD control.)
- During search, still, or frame-by-frame playback, the picture will be distorted, and there may be loss of colour.

ATTENTION:
When this recorder is connected to a multi-system TV, it may happen that no colours appear on the screen if the colour system select switch of the TV is adjusted to the AUTO position. In such a case, change the setting of the colour system select switch on the TV to the position which corresponds to the setting (K, I) of the RF converter system select switch on the rear panel of the recorder.

Tape-to-tape editing

There are 4 different types of recorded tape, depending on the signal recorded.

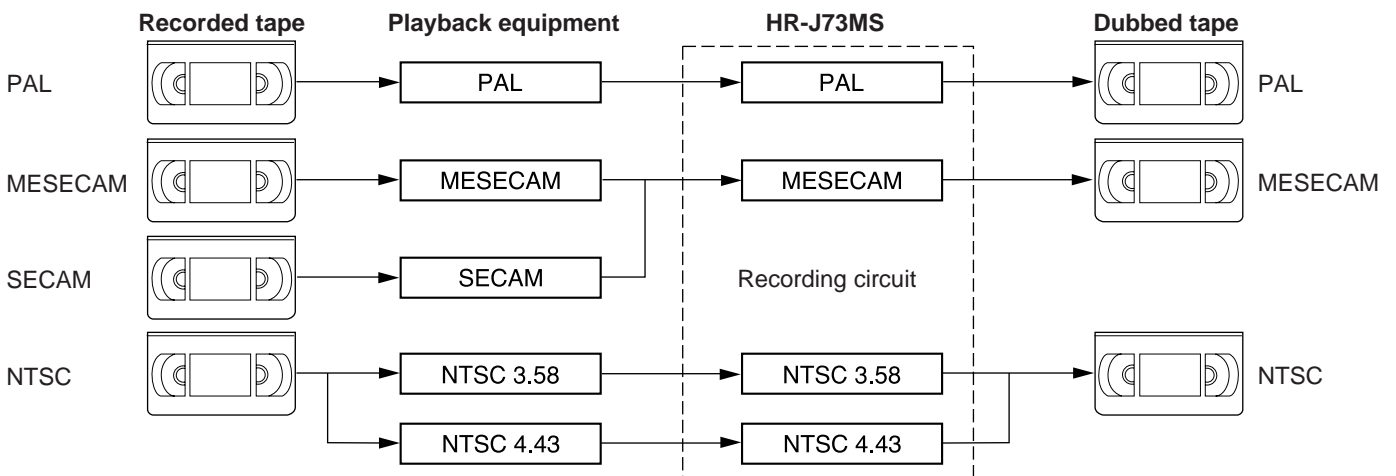

Troubleshooting

POWER AND TAPE TRANSPORT PROBLEMS

Symptoms	Check point
No power is applied to the recorder.	<ul style="list-style-type: none"> ■ Is the power cord disconnected? – Connect it.
Clock is functioning properly, but the recorder cannot be powered.	<ul style="list-style-type: none"> ■ Is "TIMER" displayed on the display panel? – Press the TIMER button to extinguish the display.
Tape stops during rewind or fast-forward.	<ul style="list-style-type: none"> ■ Is the C. MEMORY button pressed? – Press again to make "M" disappear from the display panel.

RECORDING PROBLEMS

Symptoms	Check point
Recording cannot be started.	<ul style="list-style-type: none"> ■ Is a cassette loaded? ■ Is the safety tab on the cassette removed? – Reseal the slot with adhesive tape.
TV broadcasts cannot be recorded.	<ul style="list-style-type: none"> ■ Has "AU" been selected? – Set to the desired channel.
Tape-to-tape editing or camera recording is not possible.	<ul style="list-style-type: none"> ■ Is the camcorder or another video recorder correctly connected? ■ Are all necessary power switch turned ON? ■ Has "AU" been selected? – Set to "AU".
Timer recording is not possible.	<ul style="list-style-type: none"> ■ Have you set the clock correctly and programmed the timer correctly? – Check once again. ■ Is "TIMER" displayed on the display panel? – If not, press the TIMER button to display "TIMER".

PLAYBACK PROBLEMS



Symptoms	Check point
Playback picture does not appear while the tape is running.	<ul style="list-style-type: none"> ■ If you are using RF OUT connection, is the TV receiver's channel selector set to the correct video channel? – Set it to the RF converter channel (UHF 25). (☞ p.8) ■ If you are using AV connection, is the TV receiver set to the AV mode? – Set it to the AV mode.
Noise appears during visual search.	<ul style="list-style-type: none"> ■ This is normal.
Noise appears during normal or slow-motion playback.	<ul style="list-style-type: none"> ■ Is the automatic tracking mode engaged? – Try manual tracking. (☞ p.12)
Playback picture is blurred or interrupted while TV broadcasts are clear.	<ul style="list-style-type: none"> ■ Video heads may be dirty. – Head cleaning is necessary. Consult your JVC dealer. (☞ p.3)
No sound accompanies the playback picture.	<ul style="list-style-type: none"> ■ Is the SYSTEM switch set to the correct position? – Set it to the correct position for the TV broadcast system used in your area (☞ p.7)

KARAOKE PROBLEMS

Symptoms	Check point
No sound from the microphone is heard.	<ul style="list-style-type: none"> ■ Is the microphone volume adjusted at the lowest level? (☞ p.22)
Direct access song search (BLANK SEARCH) does not work properly.	<ul style="list-style-type: none"> ■ If the tape does not have a signal on its normal soundtrack, if the length of blank parts between tunes is too short, if the tune fades out at the end, or if the tape contains excessive noise signals, BLANK SEARCH may not work properly with that tape. – Try Index search. (☞ p.13)

Troubleshooting (cont'd)

OTHERS

Symptoms	Check point
Sound noise is heard during NICAM signal receiving. (There is no NICAM tuner in this VCR.)	<ul style="list-style-type: none"> ■ Press the Pause/Still button more than two seconds in accordance with step 5 of FINE TUNING. ( p.10 Fine-tuning channels already stored.) – NICAM SUPPRESSION function works after “*” indication. – Press the STORE button. 
Whistling or howling is heard from TV during camera recording.	<ul style="list-style-type: none"> ■ Move camcorder or camera's microphone away from TV or reduce TV sound volume.
Channel cannot be switched.	<ul style="list-style-type: none"> ■ Is recording in progress? <ul style="list-style-type: none"> – Press the Pause/Still button, change the channel, and press the Play ▶ button.
Remote control does not function.	<ul style="list-style-type: none"> ■ Are the batteries discharged? <ul style="list-style-type: none"> – Replace with new ones.
Index Search does not function properly.	<ul style="list-style-type: none"> ■ Adjacent index codes may be too close to each other. <ul style="list-style-type: none"> – Erase some index codes and mark new ones if necessary, with sufficient distance between any two index codes.

Specifications

GENERAL

Power requirement	AC110 – 240~, 50/60 Hz
Power consumption	24 W
Temperature	
Operating	5°C to 40°C
Storage	-20°C to 60°C
Dimensions (W × H × D)	435 × 105 × 351 (mm)
Weight	4.9 kg
Format	VHS standard
Maximum recording time	
SP	240 min. with E-240 video cassette (PAL/MESECAM) 160 min. with T-160 video cassette (NTSC)
LP	480 min. with E-240 video cassette (PAL/MESECAM)
EP	480 min. with T-160 video cassette (NTSC)

VIDEO

Signal system	PAL-type colour signal and CCIR monochrome signal, 625 lines/50 field NTSC colour and EIA monochrome signals, 525 lines/60 fields
Recording/Playback system	DA-4 (Double Azimuth) head helical scan system
Signal-to-noise ratio	43 dB
Horizontal resolution	240 lines (PAL/MESECAM) 220 lines (NTSC)
Input	0.5 – 2.0 Vp-p
Output	1.0 Vp-p

AUDIO

Frequency range	70 Hz to 10,000 Hz (Normal) 20 Hz to 20,000 Hz (Hi-Fi)
Input	-8 dBs
Output	-6 dBs
MIC Input	-56 dBs

TUNER/TIMER

TV channel storage capacity	48 positions (+ AUX position “AU”)
Channel coverage	VHF Low 42 – 153 MHz CH 1 – 5 (China, Russia) High 153 – 300 MHz CH 6 – 12 (China, Russia) HYPER 300 – 470 MHz UHF 470 – 870 MHz CH 13 – 57 (China, Russia) CH 21 – 69 (U.K.)
Aerial output	UHF channels 24 – 27/ (E32 – E40) (adjustable)
Programme capacity	1-year/8-programme timer
Memory backup time	18 hours

ACCESSORIES

Provided accessories	
Aerial cable	1
Infrared remote control unit	1
“AA/UM-3” battery	4
“AAA/UM-4” battery	2
Conversion plug	1
Wireless microphone	1
Wired/Wireless microphone	1

- Specifications shown are for SP mode unless otherwise specified.
- Design and specifications subject to change without notice.

